

Wraps Anything Tighter

The **NEW G Series** low-volume stretch wrapper from Lantech is a high-quality, high-performance, easy-to-use machine that makes safe to ship loads.



TIGHTER = SAFER

Your reputation rests on what you deliver to your customers. Make sure your pallet loads are safe to ship. The Patent Pending **G Force Film Delivery System** combined with easy to understand and use controls, gives you professional results on every load.



IT'S A LANTECH

No compromises! Legendary Lantech durability and performance built in to every G Series stretch wrapper, backed by a 3-year unlimited cycle warranty.



G FORCE FILM DELIVERY SYSTEM

Tension release let's you reduce tension so the film doesn't pull out when you start wrapping.

Turn tension knob clockwise to increase film tension and counter clockwise to reduce film tension.



WRAP CYCLE PAUSE

Stop the machine whenever you want, and start right where you left off, without resetting the machine.

Used for inserting labels, corner protection, etc.



BANDING MODE

Stops roll carriage at selected areas and applies selected number of film revolutions.

Used in cases where manual film manipulation is desired.



G SERIES Specifications

PERFORMANCE CRITERIA

■ Peak Production Speed	Application Specific
■ Turntable Speed (Variable)	10 RPM Max
■ Turntable Drive	.75 HP TEFC (AC)

LOAD HANDLING SYSTEM

■ Turntable, Smooth Top	65 inch (165.1 cm) Diameter
■ Maximum Load Diagonal/Dimensions	72 inch (182.88 cm) Recommended*
■ Maximum Load Height	90 inch (228.6 cm)
■ Maximum Load Weight	3500 lbs (1588 kg)

FILM DELIVERY SYSTEM

■ Film Delivery System	Brake Roller
■ Tension Control	3 to 30 lbs (1kg to 14kg)
■ Film Capacity	10 inch (25.4 cm) Roll Diameter
■ Standard Film Width	20 inch (50.8 cm)
■ Photoeye Load Sensing	Standard

MACHINE SHIPPING WEIGHT

■ Approximate Weight	Machine Weight 850 lbs. (386 kg)
■ Shipping Weight	950 lbs (612 kg)

ELECTRICAL REQUIREMENTS

■ Machine Voltage	115V, 20A Standard
■ Wrap Cycle Pause	Standard
■ One Way Wrap	Standard

SERVICE SUPPORT

24 hrs/7 days a week

PHONE NUMBER

800-866-0322

Specifications subject to change without notice. Lantech systems and sub-systems are protected by U.S. and foreign patents. Additional U.S. and foreign patents pending. © Lantech 2013

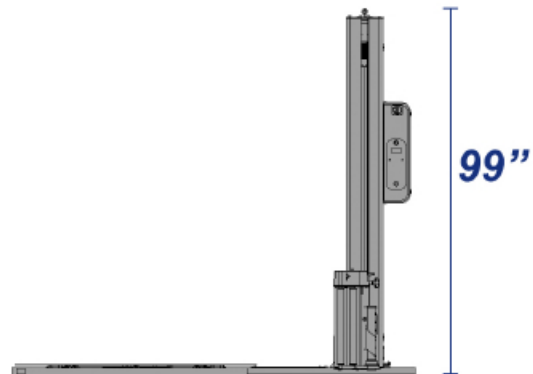
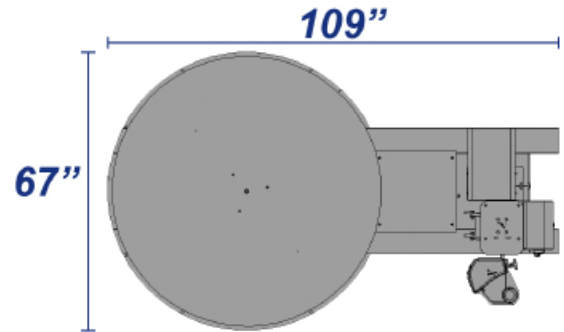

G Series

Lantech®

11000 Bluegrass Pkwy
Louisville, KY 40299-2399 USA
800-866-0322
www.lantech.com

